

EVANS

CAPACITOR COMPANY



TDD Series Hybrid Capacitors

Product Datasheet

12.18.2020



Product Overview

The capacitor shall utilize sintered tantalum anodes and ruthenium oxide coated cathodes operating in aqueous electrolyte. The components shall be hermetically sealed in a welded tantalum case with a glass-to-metal seal.

The TDD Series comes in a 1.4” x 1.4” square case and has the highest power density of any tantalum capacitor technology.

Electrical Specifications

Rated Voltage Range	10VDC to 125VDC
Capacitance Range	1,500uF to 240,000uF
Life (@85°C)	>2000 hours @ Rated Voltage

Mechanical Specifications

Test	Method	Condition	Remarks
Shock	MIL-STD-202 METHOD 213	G	Tested for 11ms at 50g
Vibration	MIL-STD-202 METHOD 204	D	12 sweeps/axis, 20g peak
	MIL-STD-202 METHOD 214	II, Letter E	1.5 hours/axis, 19.64g peak
Moisture Resistance	MIL-STD-202 METHOD 106		6V Polarity

Solderability	To ANSI J-STD-002
Operating Temperature Range	-55°C to +85°C or 125°C with voltage derating (see page 3)
Storage Temperature Range	-62°C to +130°C

Thermal Dissipation

In free air, TDD SERIES exhibit a case temperature rise of approximately 20°C per watt dissipated.

Capacitor Life

TDD Series capacitors are rated for >2,000 hours at 85°C and rated voltage or 125°C at de-rated voltage. The effective life of a capacitor in a given application is based on the specific operating voltage and average temperature.

TDD Series Capacitors have an unlimited Shelf life.

Environmental Compliance

All TDD ratings are RoHS 5/6 compliant to EU RoHS Directive 2011/65/EU.

- Negative terminal is 60/40 SnPb plated copper wire
- Positive Terminal is 60/40 SnPb plated Nickel Tube

Handling Guidelines

Attachment / Mounting by leads only is discouraged in applications exposed to mechanical shock or vibration. Always ensure capacitor is firmly secured to PWB, by either mounting studs, epoxy staking or both (preferred for vibration environments)

- Provide adequate care to protect the glass to metal seal (GTMS)
 - Avoid forces on the positive terminal, lateral, axial or torque.
 - Avoid mechanical shock to the positive terminal.
 - Secure the part to PWB before soldering
- Mounting with studs
 - #2-56 CDA-752 studs are available as a standard option.
 - Use spacers (provided) to fill the gap between PWB and leaded surface of capacitor.
 - Tighten Studs to 30-40 in-oz.
 - Secure nuts (provided) with red Loctite. Do not use lock washers.
- Potting / Epoxy Staking
 - We advise epoxy staking capacitor to PWB even when using studs, for maximum vibration tolerance.
 - In some applications it may be advisable to pot the cavity between the PWB and leaded surface.
 - Highest shock/vibration applications may require the capacitor to be fully potted.
- Soldering
 - Rim of capacitor is intended to mate directly to PWB. Advise using "no-clean" flux.
 - Utilize ANSI J-STD 001 Standard Through hole Soldering methods.
- Lead trimming
 - Provide adequate care if leads must be trimmed.
 - Trimming the positive terminal is not recommended.
 - Lead lengths available in 1/32" increments from 0.125" when measured from the rim of the capacitor.

Recommended PWB Layout with Minimum PTH Diameters

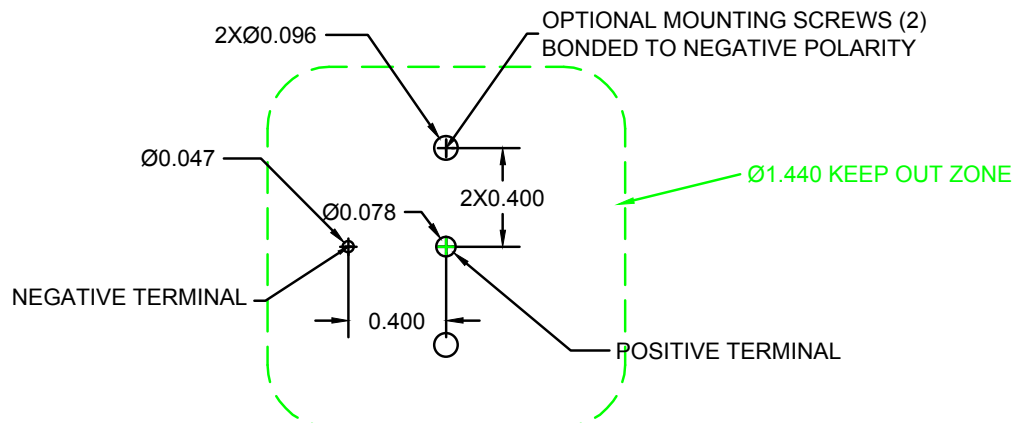

Part Number Description

<i>Product Series</i>	<i>Voltage Rating</i>	<i>Cap Rating</i>	<i>Option: Custom Center Lead</i>	<i>Option: ±10% Rating</i>	<i>Option: Stud Mount</i>
TDD#	XXX	XXX	LX	K	SMXX

Ratings Table

Part Number	DLA PN	Voltage 85°C	Voltage 125°C	Cap (µF)	ESR (mΩ)	Height (in)	Mass (g)
TDD1010603	15010-01	10	6	60,000	30	0.31	55
TDD2010124	15010-02	10	6	120,000	20	0.45	80
TDD3010184	15010-03	10	6	180,000	15	0.6	108
TDD4010244	15010-04	10	6	240,000	12	0.75	134
TDD1016403	15010-05	16	9.6	40,000	30	0.31	55
TDD2016803	15010-06	16	9.6	80,000	20	0.45	80
TDD3016124	15010-07	16	9.6	120,000	15	0.6	108
TDD4016164	15010-08	16	9.6	160,000	12	0.75	138
TDD1025243	15010-09	25	15	24,000	30	0.31	55
TDD2025483	15010-10	25	15	48,000	20	0.45	80
TDD3025723	15010-11	25	15	72,000	15	0.6	108
TDD4025963	15010-12	25	15	96,000	12	0.75	134
TDD1035163	15010-13	35	21	16,000	40	0.31	55
TDD2035323	15010-14	35	21	32,000	20	0.45	80
TDD1050113	15010-17	50	30	11,000	50	0.31	55
TDD1063472	15010-21	63	38	4,700	50	0.31	60
TDD2063942	15010-22	63	38	10,000	25	0.45	86
TDD3063143	15010-23	63	38	14,000	17	0.6	115
TDD1080302	15010-25	80	48	3,000	55	0.31	60
TDD2080602	15010-26	80	48	6,000	27	0.45	86
TDD3080902	15010-27	80	48	9,000	17	0.6	115
TDD1100222	15010-29	100	60	2,200	65	0.31	60
TDD1110202		110	66	2,000	100	0.31	60
TDD1125152	15010-33	125	75	1,500	100	0.31	60

2D Drawing

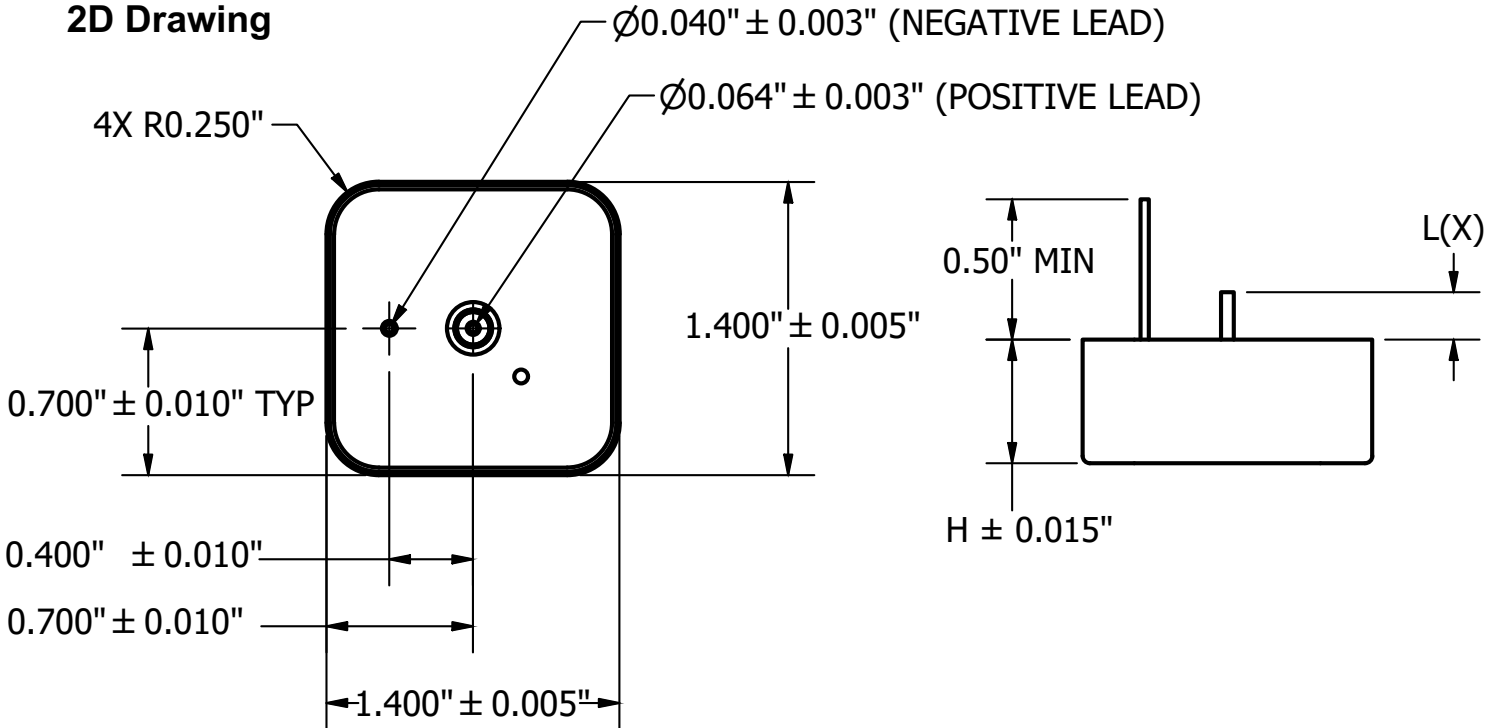

	TDD1	TDD2	TDD3	TDD4
Case Height (H)	0.312"	0.450"	0.600"	0.755"

	L0	L1	L2	L3	Standard	L4	L5	L6
Length L(x)	0.125"	0.156"	0.188"	0.219"	*0.230"	0.250"	0.281"	0.313"

*If unspecified, standard center lead length is 0.230+/-0.030"
L(x) dimensions are +/-0.010"

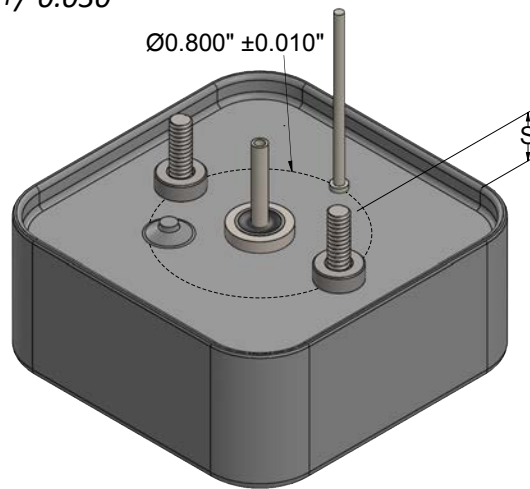

STUD MOUNT OPTION
CDA752 #2-56
EXAMPLE: TDDXXXXXXSM00

SUFFIX	SM00	SM01	SM02	SM03	SM04	SM05
Stud Height (S) +/- 0.020"	0.21"	0.27"	0.40"	0.15"	0.18"	0.35"

Average Electrical Performance

Typical Capacitance vs Temperature
120 Hz

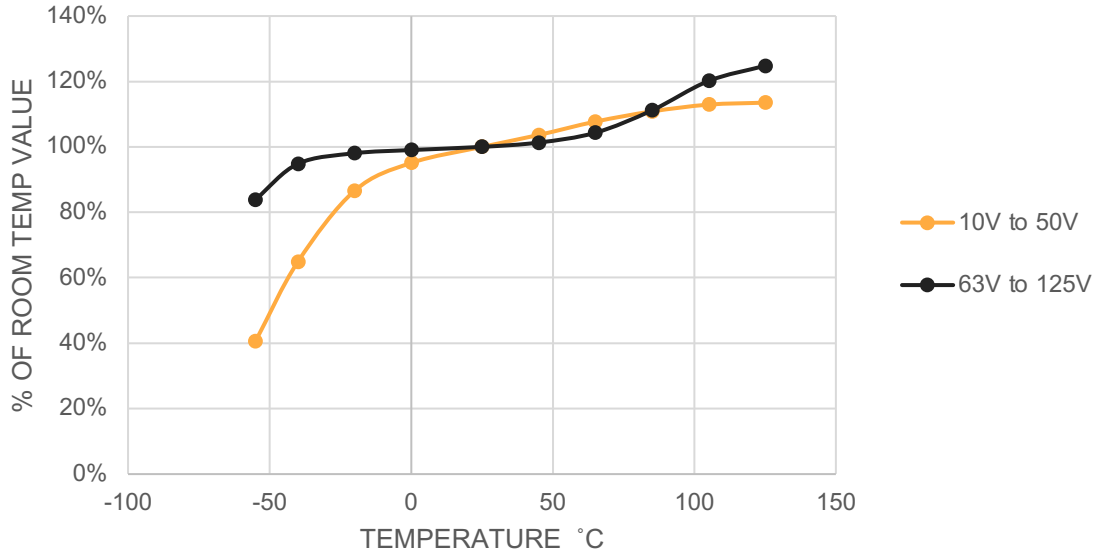

Typical ESR vs Temperature
1 KHz

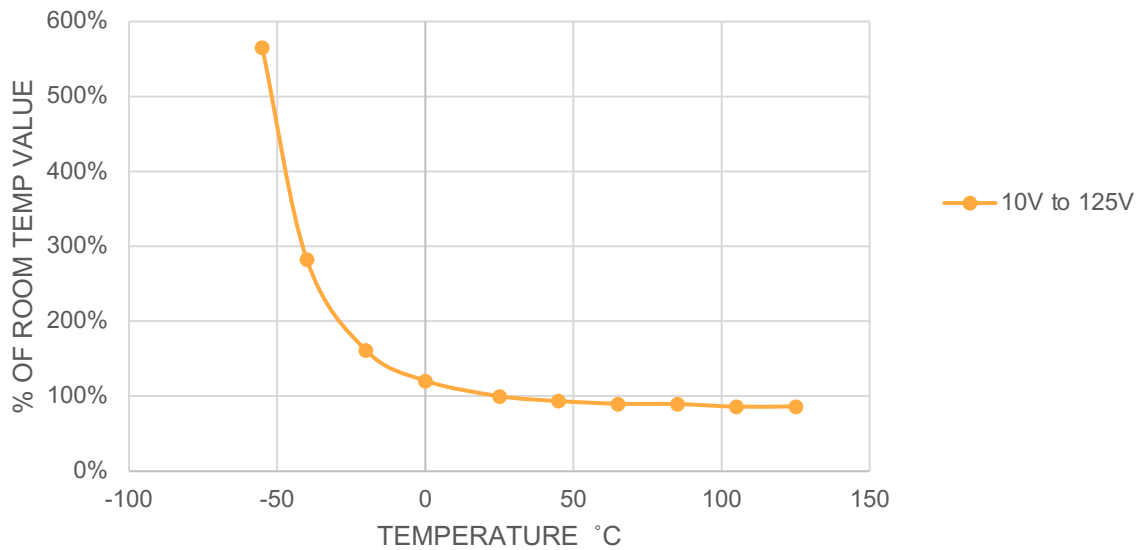

Inductance vs Freq

